

PLEASE CALL IF YOU ARE MISSING ANY PARTS OR HAVE ANY QUESTIONS REGARDING THE SAFE OPERATION OF THIS PRODUCT. (574-848-7491 OR 800-294-0671)

APPELEZ SI VOUS MANQUEZ N'IMPORTE QUELLES PIECES OU VEUILLEZ AYEZ TOUTES LES QUESTIONS CONCERNANT L'EXPLOITATION SURE DE CE PRODUIT. (574-848-7491 OR 800-294-0671)

LLAME SI USTED ESTÁ FALTANDO CUALESQUIERA PIEZAS O TENGA POR FAVOR CUALQUIER PREGUNTA CON RESPECTO A LA OPERACIÓN SEGURA DE ESTE PRODUCTO. (574-848-7491 OR 800-294-0671)

EarthWay

EV-N-SPRED

GT

ASSEMBLY and OPERATING INSTRUCTIONS
for Model **3100** Broadcast Spreader

DIRECTIVES D'ASSEMBLAGE
et D'UTILISATION

pour Model **3100** Épandeur Centrifuge

INSTRUCCIONES de la ASAMBLEA y
de FUNCIONAMIENTO

para Modelo **3100** Sembrador o
Esparcidor

OPERATING INSTRUCTIONS

Before filling hopper, become familiar with the operation of this spreader.

- Obtain proper setting for material to be used from the SETTING MATRIX included with this spreader.
- Move stop bolt on rate gauge assembly to the proper setting.
- While turning handle crank and walking forward, push control lever forward to the stop bolt. To stop, pull lever back to close flow holes while continuing to crank handle and walking forward.
- When finished, empty any remaining material from hopper.
- Thoroughly wash spreader and allow to dry before storing.
- No oiling is necessary.

DIRECTIVES D'UTILISATION

Avant de remplir la trémie, familiarisez-vous avec le mode d'emploi de l'épandeur.

- Consultez le TABLEAU DE RÉGLAGE afin de savoir lequel utiliser selon le type de produit que vous appliquez.
- Placez le boulon d'arrêt au bon réglage sur le sélecteur.
- En tournant le fanatique de poignée et en marchant en avant, le levier de contrôle de poussée envoie au verrou d'arrêt. S'arrêter, retenir le levier pour fermer des trous d'écoulement en continuant à lancer à la manivelle la poignée et en marchant en avant.
- Lorsque vous avez terminé, videz complètement la trémie.
- Nettoyez l'épandeur à fond et laissez-le sécher avant de le ranger.
- Il ne nécessite aucun huilage.

INSTRUCCIONES DE FUNCIONAMIENTO

Antes de llenar la tolva, conviértase al corriente de la operación de este esparcidor.

- Obtenga el ajuste apropiado para que el material sea utilizado de la TARIFA QUE FIJA LA CARTA incluida con este esparcidor.
- Mueva el perno de la parada en el montaje de galga de la tarifa al ajuste apropiado.
- Girando el mango arrancan con la manivela y andando avanzado, palanca de control de empuje avanzada al cerrojo de parada. Pararse, retirar la palanca para cerrar el flujo agujerea siguiendo arrancando con la manivela el mango y andando avanzado. Cuando está acabado, vacié cualquier material restante de la tolva.
- Lave a fondo el esparcidor y permita para secarse antes de almacenar.
- No hay el engrasar necesario.

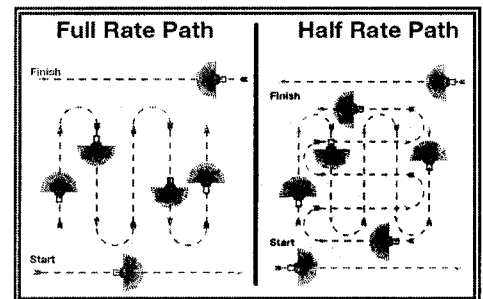
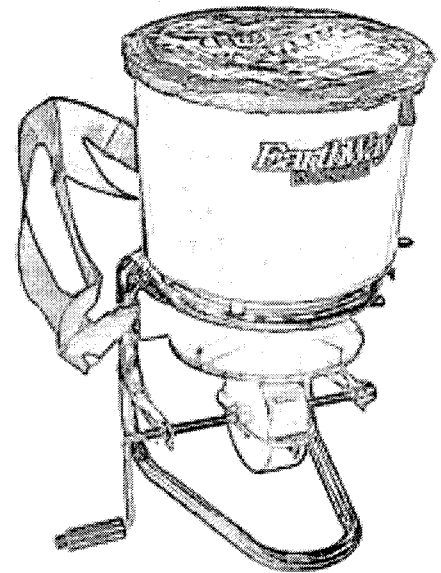

The settings furnished on the Rate Setting Chart are intended as a guide only. Variations in physical characteristics of material applied, walking speed, and roughness of ground surface may require slightly different spreader settings. Due to the above conditions, there is no warranty as to the uniformity of coverage actually obtained from the settings listed.

Les arrangements meublés sur le taux plaçant le diagramme sont prévus comme guide seulement. Les variations des caractéristiques physiques de matériel appliquées, de la vitesse de marche, et de la rugosité de la surface au sol peuvent exiger les arrangements légèrement différents d'écarteur. En raison des conditions ci-dessus, il n'y a aucune garantie quant à l'uniformité de l'assurance réellement obtenue à partir des arrangements énumérés.

Los ajustes equipados en la tarifa que fija la carta se piensan como guía solamente. Las variaciones en las características físicas del material aplicadas, la velocidad que camina, y la aspereza de la superficie de tierra pueden requerir ajustes levemente diversos del esparcidor. Debido a las condiciones antedichas, no hay garantía en cuanto a la uniformidad de la cobertura obtenida realmente de los ajustes enumerados.

EarthWay EV-N-SPRED GT

EarthWay Products, Inc.

P.O. Box 547
Bristol, IN 46507
(574) 848-7491
or
800-294-0671

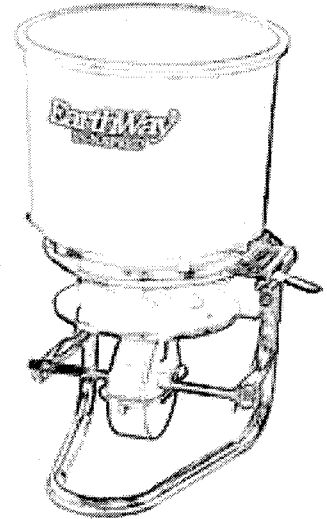
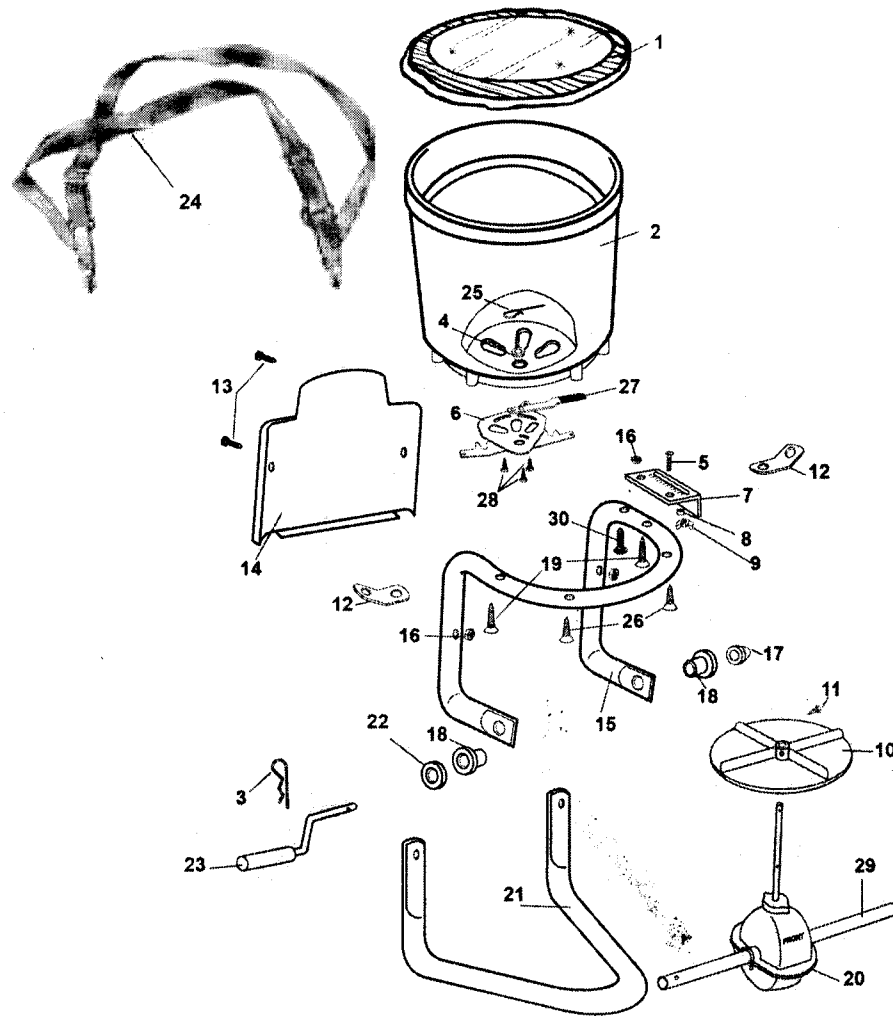

3100 Parts List

Key #	Part #	Description	Key #	Part #	Description	Key #	Part #	Description
1	77000	Heavy Duty Rain Cover	11	31103	#6x1/2" Type 25 HWHS	21	23600	Stand
2	13103	Hopper Assembly	12	44226	Harness Clip	22	34103	1" OD Washer
3	33110	Hair Pin Clip	13	37101	1/4-20 x 1-1/2" Carriage Bolt	23	60124	Handle Crank Assembly
4	12220	Hopper Bushing	14	12188	Belly Guard	24	60121	Harness Assembly
5	37103	#10-24 x 3/4" Carriage Bolt	15	23103	Frame	25	33117	Agitator
6	60128	Shut-Off & Lever Assembly	16	32100	1/4-20 Hex Nut	26	31108	#10 x 1-1/4" Screw
7	41262	Flow Gauge	17	12166	Crank Shaft Cap	27	19114	Grip
8	12147	Spacer	18	12137	Split Bearing	28	31138	#8 x 3/8" PMT Screws
9	32106	1/4-20 Wing Nut	19	31128	#10 x 1-1/2" Screw	29	23608	Crank Shaft
10	12109	Impeller	20	60126	Gearbox Assembly	30	37109	1/4-20 x 1-1/4" Carriage Bolt

5-YEAR LIMITED WARRANTY

EarthWay Products, Inc. warrants this product free of defects in original workmanship and materials for a period of 5-Years to the end user with the original purchase receipt. If a manufacturing non-conformance is found, EarthWay Products, Inc. at its discretion will repair or replace the part(s) or product at no charge provided the failure is not the result of incorrect installation, mishandling, misuse, tampering, or normal wear and tear as determined by EarthWay. EarthWay at its discretion may require that the part(s) or product be returned along with the original purchase receipt at owners' expense for examination and compliance with the terms of this warranty. (Do not return any product without first receiving authorization from EarthWay Products, Inc.). To seek remedy under this warranty, contact EarthWay Products, Inc. at 574-848-7491, techsupport@earthway.com or write to (EarthWay Products, Inc. P.O. Box 547 Bristol, Indiana 46507) and describe the nature of the manufacturing defect. SPECIFIC LIMITATIONS: This warranty covers only the part(s) or product; any labor charges associated with repair or replacement of non-conformances are specifically excluded. Due to the corrosive nature of most fertilizers and ice melt products, EarthWay Products, Inc. makes no warranty against and specifically excludes part(s) or product degradation or failure due to corrosion or its effects. Clean and dry your spreader thoroughly after each use, as a preventative measure, coat all metal parts with a light oil or silicon spray.