

MODEL # 6500

ASSEMBLY INSTRUCTIONS



### HIGH-WHEEL CULTIVATOR

Congratulations on the purchase of your new EarthWay High-Wheel Cultivator.

Please contact us if you have any difficulty with assembly or operation of this product.

We can be reached at [support@earthway.com](mailto:support@earthway.com) or by calling 574-848-7491 Monday - Friday 8:00am - 4:30pm or visit us online at [www.earthway.com](http://www.earthway.com)

The 6500 comes with lifetime technical support.

## HELPFUL HINTS

- The 6500 will require approximately 30 minutes to assemble with common hand tools.
- Remove and identify all loose parts from carton.
- Clean and dry your Cultivator thoroughly after each use.
- Coat all metal surfaces with a light oil to prevent corrosion.

## CUSTOMER SERVICE

[SUPPORT@EARTHWAY.COM](mailto:SUPPORT@EARTHWAY.COM) | [www.EARTHWAY.com](http://www.EARTHWAY.com) | 1009 Maple Street, Bristol, IN 46507

## ONE YEAR WARRANTY

EarthWay Products, Inc. warrants this product free of defects in original workmanship and materials for a period of one year to the end user with the original purchase receipt. If a manufacturing non-conformance is found, EarthWay Products, Inc. at its discretion will repair or replace the part(s)/product at no charge provided the failure is not the result of incorrect installation, mishandling, misuse, tampering, or normal wear and tear as determined by EarthWay.

EarthWay at its discretion may require that the part(s) or product be returned along with the original purchase receipt for examination and compliance with the terms of this warranty. Do not return any product without first receiving authorization from EarthWay Products, Inc.

To seek remedy under this warranty, contact EarthWay Products, Inc. at 574-848-7491, [support@earthway.com](mailto:support@earthway.com) or write to EarthWay Products, Inc. 1009 Maple Street, Bristol, IN 46507 and describe the nature of the manufacturing defect.

**SPECIFIC LIMITATIONS:** This warranty covers only the part(s) or product; any labor charges associated with repair or replacement of non-conformances are specifically excluded. Due to the corrosive nature of most fertilizers and ice melt products, EarthWay Products, Inc. makes no warranty against and specifically excludes part(s) or product degradation or failure due to corrosion or its effects.

**ASSEMBLY HARDWARE**

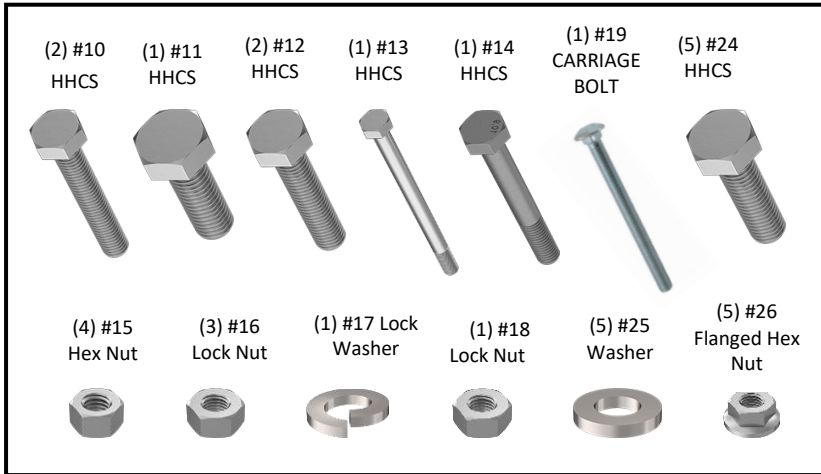

**ASSEMBLY INSTRUCTIONS**

- Assemble both (#4) Upper and (#3) Lower Handles together and secure with (#12) hex bolt & (#15) hex nut – do not tighten.
- Assemble (#7) Left and (#6) Right Tool Supports, by positioning (#9) Tool Support Spacer between them at the end that has only one hole as shown in the exploded view, secure using (#11) hex bolt and (#15) hex nut and tighten. Make sure you have the Right and Left in the correct position as shown in the exploded view.
- Connect (#2) Frame to the Tool Support Assembly from step 2 using (#14) hex bolt thru the (#2) Frame and then through both (#6 & #7) Tool Supports, then through (2) Frame on the other side and secure with (#16) lock nut, and tighten.
- Install (#8) Cross Brace on to the Upper Handle and secure with (#10) hex bolt and (#16) lock nut to each side, loosely tighten.
- Install (#5) Axle into (#23) Wheel and position between the (#2) Frame rails.
- Now insert (#13) hex bolt through the hole in (#3) Lower Handle, (#2) Frame, then into (#5) Axle & (#23) Wheel, then (#2) Frame, (#3) Lower Handle and secure with (#17) Lock Washer & (#15) hex nut, and tighten.
- Now determine a comfortable operation height and then remove (#15) hex nut and select one of the four adjustment holes in the top of (#6 & #7) Tool Supports and secure with (#15) hex nut and tighten.

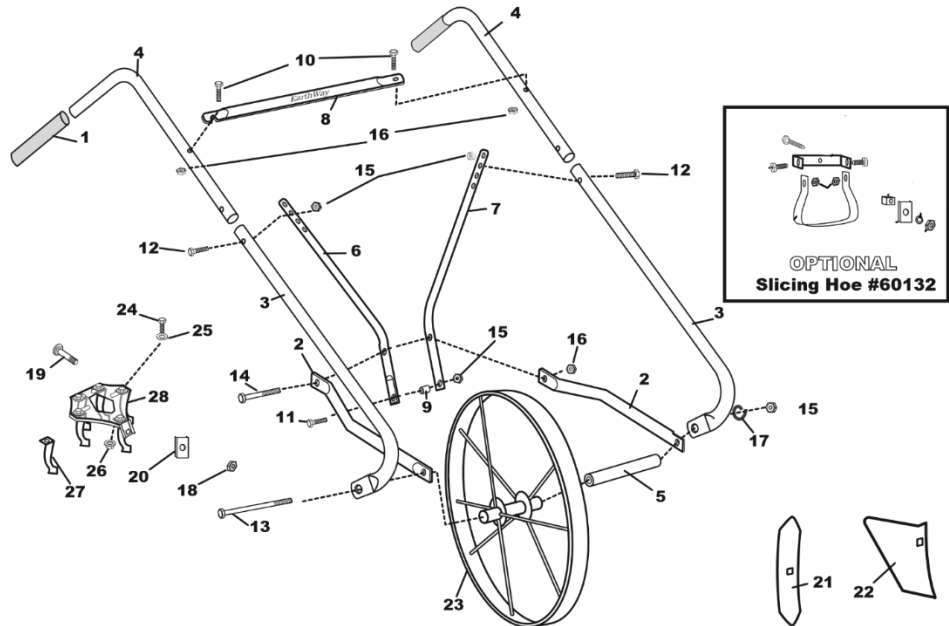

**PARTS DIAGRAM**

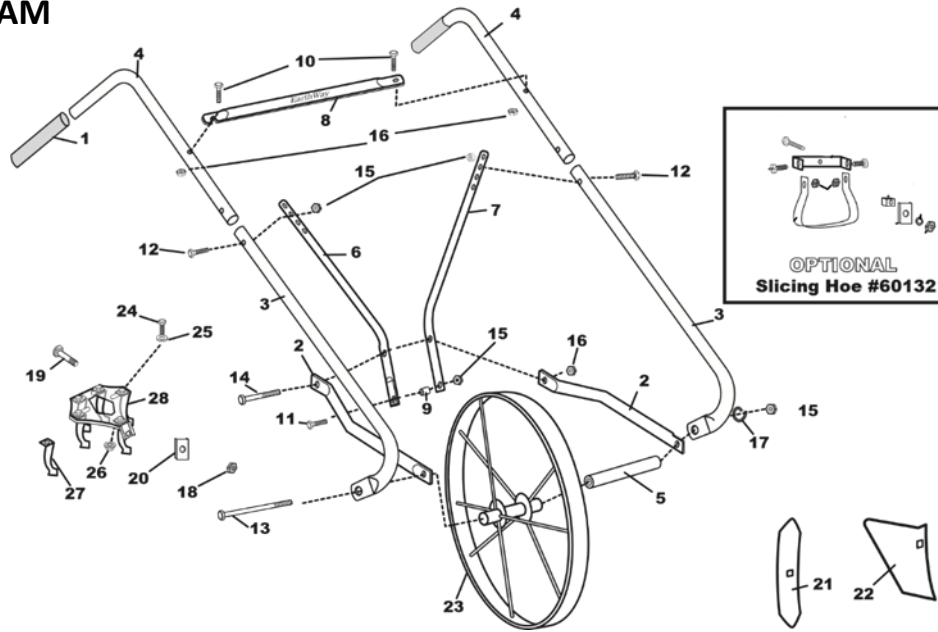

Updated parts diagrams and ordering can be accomplished by visiting [www.earthway.com](http://www.earthway.com)

KEY	QTY	DESCRIPTION	KEY	QTY	DESCRIPTION
1	2	1"ID X 4.5"IL BLACK GRIP	17	1	M8 LOCK WASHER ZINC
2	2	FRAME	18	1	M10 LOCKNUT
3	2	LOWER HANDLE	19	1	M10 X 50MM CARRIAGE BOLT ZINC
4	2	UPPER HANDLE	20	1	FORMED WASHER
5	1	AXLE	21	1	FURROW PLOW
6	1	RIGHT TOOL SUPPORT	22	1	HILLING (MOLDBOARD) PLOW
7	1	LEFT TOOL SUPPORT	23	1	WHEEL ASSEMBLY
8	1	CROSS BRACE	24	5	M8 X 25MM HHCS ZINC
9	1	TOOL SUPPORT SPACER	25	5	M8 FLAT WASHER ZINC
10	2	M6 X 40MM HHCS ZINC	26	5	M8 FLANGED HEX NUT ZINC
11	1	M8 X 30MM HHCS ZINC	27	5	CULTIVATOR TINE (5 REQUIRED)
12	2	M8 X 40MM HHCS ZINC	28	1	MOUNTING PLATE
13	1	M8 X 120MM HHCS ZINC			
14	1	M6 X 50MM HHCS ZINC			
15	4	M8 HEX NUT ZINC			
16	3	M6 LOCKNUT ZINC			
			<b>60132</b>		<b>OPTIONAL SLICING HOE ASSEMBLY</b>
			29	1	SLICING HOE BLADE
			30	1	1/4-20 X 3/4" HHMS ZINC
			31	1	SLICING HOE BRACKET
			32	1	5/16-18 X 2" HX TAP BOLT ZINC
			33	1	TOOL ADAPTOR FOR SLICING HOE