

AIR-SPADE®

**SERIES 2000
OPERATOR'S MANUAL**



A DIVISION OF

GUARDAIR®
CORPORATION

Technical Specifications	3
General Information	4-5
Safety Instructions	6-7
Assembly Instructions	8
Operating Instructions	9-11
Components & Accessories	12-14
Parts Disassembly and Reassembly	15-16
Products, Parts & Accessories List	17
Limited Warranty	18

AIR-SPADE SERIES 2000

- Overall Length 60.5 inches (154 cm)
- Weight 7.1 pounds (3.2 kg)
- Nozzle Extra-hardened stainless steel
- Nozzle Flow Rates
 - 25 scfm (0.7m³/min)
 - 60 scfm (1.7m³/min)
 - 105 scfm (3.0m³/min)
 - 150 scfm (4.2m³/min)*
 - 225 scfm (6.4m³/min)
- Operating Pressure 90 psi (6.2 bar)
- Barrel Insulated fiberglass
- Inlet 3/4" FNPT
- Inlet Connector 3/4" Chicago style

**Standard Model*



AIR-SPADE® is a registered trademark of Guardair Corporation.



Always wear eye and ear protection when operating air tools and related equipment.

AIR-SPADE is covered by U.S. Patents 5,782,414, D408,830, and D435,207.

GUARDAIR CORPORATION'S AIR-SPADE Series 2000 is a compressed air-powered tool used for excavation of a wide variety of soils. AIR-SPADE Series 2000 consists of an ergonomic pistol grip style handle, an insulated fiberglass barrel, and a patented supersonic nozzle. Typically powered by a portable tow-behind air compressor, the AIR-SPADE Series 2000 provides a safe, powerful and efficient method of uncovering underground electric lines, pipes, and tree roots without harm. Capable of excavation where a shovel or backhoe cannot be used, AIR-SPADE can be equipped with multiple nozzle sizes and a variety of extension lengths for optimum job performance.

The heart of the AIR-SPADE is the patented supersonic nozzle which produces a focused "laser-like" jet of air moving at approximately 1,200 mph (1,900 km/hr), or nearly twice the speed of sound. This supersonic air-jet penetrates voids in the soil and expands rapidly, therefore fracturing the soil. Unlike the hard cutting edges of shovels, picks, blades, or buckets, the air-jet is harmless to non-porous items such as tree roots, buried pipes, or cables. Excavating with AIR-SPADE is much easier and many times faster than hand excavation.

The AIR-SPADE supersonic air-jet outperforms "homemade tools" featuring a pipe nipple or a crimped orifice. Air flow from these tools expands to atmosphere in an unfocused, complex manner while the supersonic air jet delivers significantly more kinetic energy and more focused momentum. In practical terms the AIR-SPADE does more work by moving more material, and harder material, in a shorter period of time.

AIR-SPADE PATENTED SUPERSONIC NOZZLE

AIR-SPADE's patented supersonic nozzle turns compressed air into a high speed, laser-like jet moving at twice the speed of sound – 1,200 mph. All of the energy and momentum of air moving at approximately Mach 2 is focused into the soil, dislodging it in a fraction of a second. **(Fig.A)** The result is faster, safer, and more efficient soil excavation.

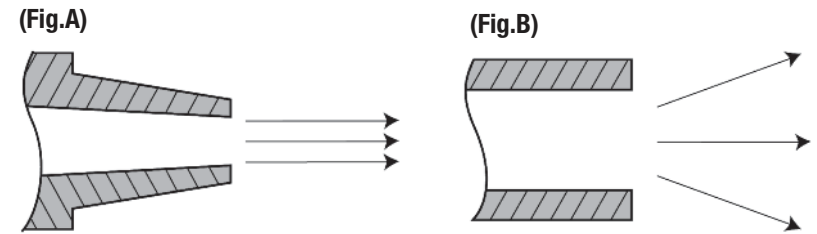

FOCUSED AIR FLOW FROM AIR-SPADE SUPERSONIC NOZZLE

UNFOCUSED AIR FLOW FROM IMPROPERLY DESIGNED NOZZLE

Air exiting from an improperly designed nozzle diffuses outward 3 to 4 times wider than the air-jet from the patented AIR-SPADE supersonic nozzle. **(Fig.B)**



Arboriculture/Horticulture



Utility/Construction



Trench Rescue



Environmental Remediation

ALWAYS

- ... **Wear** appropriate protective work clothing and equipment. Cut and puncture resistant gloves, approved safety glasses with side shields and/or face protection, and approved hearing protective earplugs or earmuffs should be worn while operating the AIR-SPADE. Eye protection should comply with ANSI Z87.1-1989. Ear protection should provide a NRR of at least 20 dB.
- ... **Wear** approved respiratory protection when working in extremely dusty conditions.
- ... **Wear** approved, electrically insulated footwear and gloves if working near underground electrical lines.
- ... **Ensure** that all personnel near the area being excavated are aware that AIR-SPADE is being used and that they wear appropriate personal protection as indicated.
- ... **Protect** surfaces that could be chipped, or damaged by dislodged soil or rock particles adjacent to the excavation work area by using suitable drop cloths, screens, or other means.
- ... **Check** the AIR-SPADE for loose or damaged parts prior to use. Tighten, repair, and/or replace as necessary.
- ... **Inspect** hoses for leakage, kinking, abrasion, corrosion, or any other signs of wear or damage. Worn or damaged hose assemblies should be replaced immediately.
- ... **Check** that the air compressor is delivering the specified pressure to operate the AIR-SPADE.
- ... **Anticipate** that the AIR-SPADE tool will push upwards when using the 45 degree adapter. Brace against the upwards force by holding the tool in accordance with the operating instructions.



- ... **Operate** the AIR-SPADE until the operating and safety instructions are read and fully understood.
- ... **Make** any modifications to the AIR-SPADE.
- ... **Tie**, tape, or otherwise lock or fasten the trigger in the “ON” position.
- ... **Point**, or aim the AIR-SPADE at any person during operation.
- ... **Allow** hands, feet, or any body parts near the AIR-SPADE nozzle tip during operation.
- ... **Use** the AIR-SPADE as a pry bar.



- Read and follow the directions below to properly assembly the AIR-SPADE.
- Apply a small amount of commercial grade anti-seize compound on the barrel threads (A & B) to prevent galling. Screw the nozzle into the barrel by turning clockwise. **Hand-tighten only.**
- Screw the barrel into the handle by turning clockwise. **Hand-tighten only.**

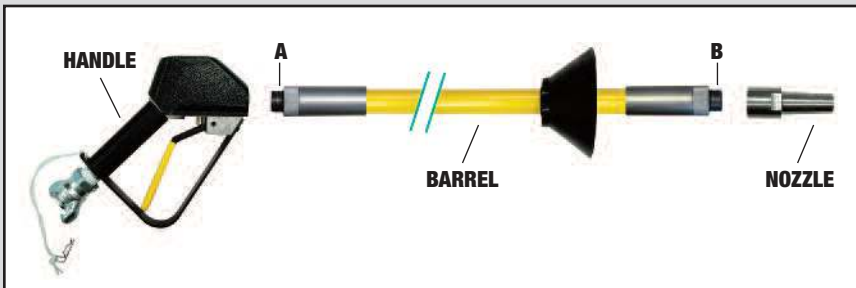

WARNING



User assumes full responsibility to read and understand these instructions prior to operation. Failure to adhere to these instructions can result in personal injury. User should also have operating knowledge of the air-compressor to which the tool is attached.

BEFORE OPERATION

- Match the air compressor size to the AIR-SPADE nozzle on the tool. To properly size the air compressor, make sure the air compressor flow rate is equal to, or greater than, the nozzle flow rate.
- Check the air compressor for sufficient fuel and oil levels.
- Make sure the air compressor is secure from accidental motion.
- Close the air supply valve on the air compressor.
- Make sure all air supply hose connections are securely made and safety clips are installed.
- Use air supply hose with a pressure rating equal to, or greater than, 150 psig.
- Use air supply hose of an appropriate diameter and length. *(See Table)*

Maximum Recommended Air Supply Hose Length (Feet)			
Nozzle Flow (scfm)	3/4" ID	1" ID	1 1/4" ID
25	4,750	≤5,000	≤5,000
60	900	3,460	≤5,000
105	240	1,110	3,350
150	110	520	1,730
225	40	220	880

STARTING

- Start the air compressor according to the manufacturer's instructions.
- The air compressor should build pressure until 100 – 120 psig is shown on the air compressor pressure gauge.
- Make sure that AIR-SPADE is turned off. Point the nozzle away from all personnel or loose objects that could become airborne. Open the air supply valve on the air compressor.
- Securely hold the AIR-SPADE. Point the nozzle up and away from all personnel and any loose objects, and depress the trigger. Read the air compressor pressure gauge and the pressure gauge on the tool. During operation the air pressure gauge on the tool should read between 80 and 100 psig (5.5 and 6.9 bar). If not, adjust the output pressure of the air compressor.

EXCAVATION PROCEDURES

- For most excavations the best performance is achieved by holding the AIR-SPADE nozzle at approximately a 45 degree angle from horizontal and about 1 inch away from the surface to be excavated.
- Depending on the soil type, the AIR-SPADE should be directed above the surface to be excavated at a rate of approximately 1 to 2 feet per second (0.3 to 0.6 meters per second).
- Except in very hard and compacted clays, dwelling on the same spot tends to reduce the rate at which material is excavated and can increase the amount of material blown away from the excavation site.
- Watering the work area ahead of time can often be helpful. Watering reduces airborne dust if the soil is extremely dry. It also reduces the soil strength making digging easier.
- For small diameter holes, position the AIR-SPADE barrel perpendicular to the ground with the nozzle close to the surface. Depress the trigger, and slowly thrust the tool into the soil. When resistance is met, slowly withdraw the AIR-SPADE and then reinsert. This procedure allows loose soil at the bottom of the hole to exit upwards. Reinsert the nozzle and repeat the above procedure until the desired depth of hole is reached.
- When boring a small diameter hole, or when plunging the AIR-SPADE into loose soil, the tendency to expose the operator to blown back material is increased. The adjustable dirt shield should be positioned close to the ground to deflect airborne material away from the operator.
- For large diameter holes, position the AIR-SPADE at an angle between 30° and 45° from the horizontal. Depress the trigger and move the AIR-SPADE back and forth across the footprint of the excavation to loosen the soil to a depth of several inches. Each layer of loose soil should then be removed with a shovel, backhoe, or vacuum. Repeat the procedure until the desired depth is reached.
- For shallow, wide excavations, position the AIR-SPADE at an angle between 30° and 45° from the horizontal. Depress the trigger, move the nozzle from side to side the desired width, and blow the loosened soil ahead of the nozzle. Continue until the excavation is completed to the required length.

- For deeper excavations or trenches loosen the soil in layers of several inches. Remove the soil with a shovel, backhoe, or vacuum. Repeat the procedure until the desired depth is reached.

- Excavation rates will vary depending upon soil composition, soil compaction, and the air delivered from the AIR-SPADE nozzle. **(See Table)**

Soil Excavation Rates	
Nozzle Flow (scfm)	Soil Excavation Rate (cubic ft / min)
25	0.4 to 0.9
60	0.7 to 1.1
105	0.9 to 1.5
150	1.2 to 1.8
225	1.7 to 2.3

- Use a portable (collapsible) barrier or fence constructed from plywood, or canvas cloth, to keep dislodged soil confined to the working area.

SHUT DOWN

- Turn off the air compressor air supply valve.
- Shut down the air compressor.
- Securely hold the AIR-SPADE. Point the nozzle up and away from all personnel and any loose objects, and depress the trigger. Continue to depress the trigger until all compressed air from the tool and hose is fully expelled and the air pressure gauge on the AIR-SPADE reads “0”.
- It is now safe to disconnect the air supply hose. Store the AIR-SPADE as desired.

MAINTENANCE

- As with any professional grade tool, the AIR-SPADE requires regular care to ensure proper operation. Prior to each use, inspect the tool for any loose or visibly damaged parts. Tighten or replace worn parts as required. Brush off dirt or other foreign material from around the trigger and valve stem areas. Periodically apply light oil or lubricant (e.g. WD40) to the exposed valve stem to ensure smooth operation.

NOZZLE

- The AIR-SPADE nozzle can be unscrewed from the barrel by turning counter-clockwise. In the event of a tighter than normal connection, flats are provided on the nozzle for wrench application. Before re-installing the nozzle, remove any dirt or foreign material from the threads and o-ring, and apply a small amount of commercial grade anti-seize compound on the threads to prevent galling. Screw the nozzle into the barrel by turning clockwise. **Hand-tighten only.**

BARREL

- The fiberglass barrel can be unscrewed from the handle by turning counter-clockwise. In the event of a tighter than normal connection, a spanner wrench may be used on the barrel if necessary. Before re-installing the barrel into the handle, remove any dirt or foreign material from the threads and o-ring, and apply a small amount of anti-seize compound on the threads to prevent galling. Screw the barrel into the handle by turning clockwise. **Hand-tighten only.**

EXTENSIONS

- Extensions provide the ability to extend the reach of the AIR-SPADE into deeper holes or trenches. To install an extension, first remove the nozzle. Apply a small amount of anti-seize compound on the threads of the barrel, then attach the extension to the barrel by screwing it into the barrel. Turn clockwise and **hand-tighten only.** Apply a small amount of anti-seize compound on the threads of the extension, then screw on the nozzle. **Hand-tighten only.**



45° ADAPTER

- The 45° adapter enables the AIR-SPADE to operate in tight locations where obstructions do not allow the use of a straight barrel. It can be installed by hand with no tools required. Remove the existing nozzle from the barrel. Ensure the 45° adapter locking ring is shouldered against the 45° adapter body and the 45° adapter coupler is snug against the o-ring. Clean the threads and the o-rings on the barrel and on the 45° adapter assembly and apply anti-seize compound to the threads of both. Screw the 45° adapter assembly onto the barrel via the coupler. **Hand-tighten only.** Screw the nozzle onto the other end of the 45° adapter. **Hand-tighten only.** To lock the adapter into position, shoulder the locking ring against the coupler.

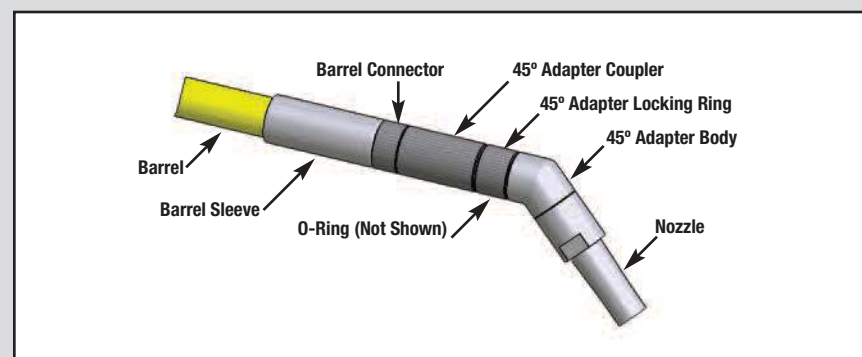

CAUTION: When using the 45° adapter, compressed air exiting the nozzle will force the tip of the tool away from the direction the nozzle is aimed. To prevent this from occurring, the operator should place the free hand at least midway down the barrel. Grip the barrel tightly to brace the tool against the force produced by the exiting compressed air.



SLIDING DIRT SHIELD

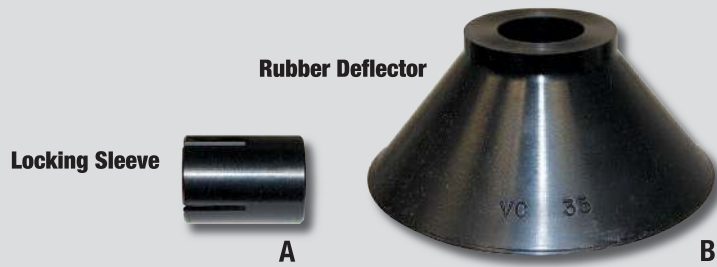

• The sliding dirt shield is made up of two components: the locking sleeve (A) and rubber deflector (B). One end of the locking sleeve has 4 slots; the other end is solid.

• To install, slide the rubber deflector over the nozzle and coupling into position (C) on the barrel. Separate the locking sleeve and clamp over the barrel in position (D). Make sure the slots are closest to the nozzle. **(Fig.1)**

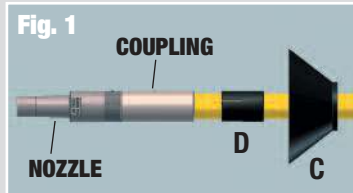

• Slide the rubber deflector so that it is positioned over the solid end of the locking sleeve. The locking sleeve and rubber deflector assembly can now slide freely up and down the barrel shaft. **(Fig.2)**

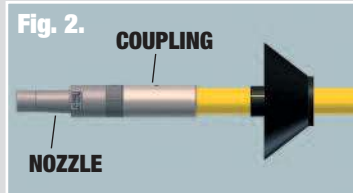

• To lock the sliding dirt shield in position, slide the assembly to the desired position on the barrel. Then firmly push the rubber deflector over the slotted end of the locking sleeve. **(Fig.3)**

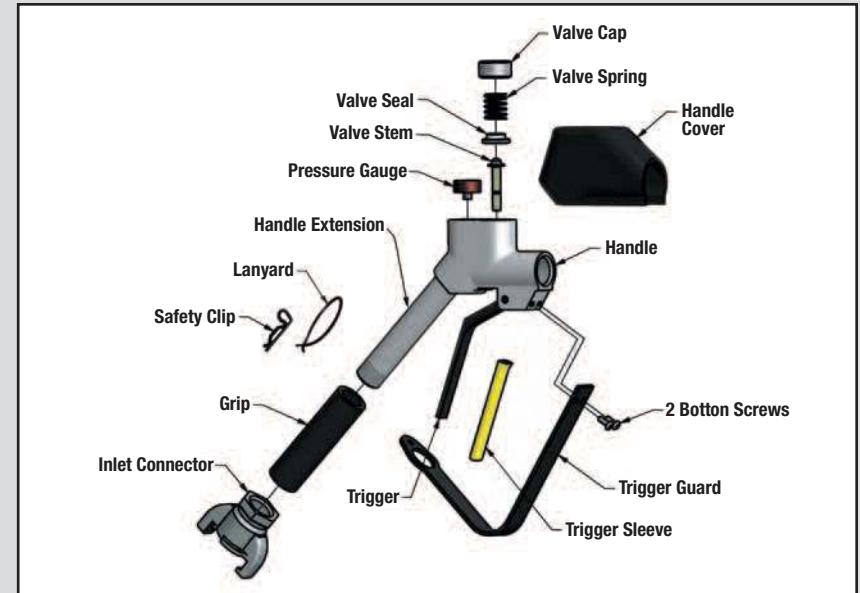
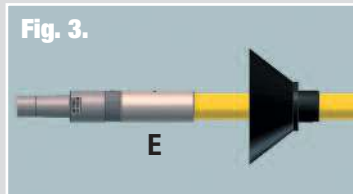

HANDLE SPARE PARTS KITS

• AIR-SPADE Series 2000 Handle Spare Parts Kit includes:

- Valve Spring
- Valve Seal
- Valve Stem
- Pressure Gauge
- Lanyard
- Safety Clip
- Grip
- Trigger Sleeve
- 2 Button Screws
- Lubricant

PRESSURE GAUGE

- The pressure gauge may be removed with a valve removal tool by turning counter clockwise. Valve removal tools are commonly available at any auto parts store. Before re-installing, apply a small amount of thread locker on the gauge stems threads. Insert the gauge into the handle cavity, turning clockwise by hand as far as possible. Tighten using the suction cup tool.

VALVE STEM

- Remove the plastic, snap-on handle cover by drawing the cover towards the rear of the tool. Unthread the valve cap (*1/2" square drive required*) and set aside. Remove and discard the valve spring, valve seal, and valve stem. Apply lubrication to the new valve stem and insert into the handle. Insert a new valve seal with the black seal face facing downwards. Insert a new valve spring. Apply Teflon tape to the threads of the existing valve cap and thread into the handle until flush. Slide the existing handle cover back in place.

INLET CONNECTOR

- Remove the plastic, snap-on handle cover. Carefully snug the AIR-SPADE handle casting in a vise. Unscrew the inlet connector by turning it counter-clockwise. Exercise caution not to unscrew the handle extension from the handle casting. Before re-installing the connector, wrap the treads of the handle extension with Teflon tape to prevent galling the threads and to insure an air-tight connection. Tighten by wrench.

TRIGGER SLEEVE AND COMFORT GRIP

- Unthread the inlet connector per the previous instructions. Remove the two button screws holding the trigger guard. Slide the trigger guard off the handle and save. Remove grip and discard. Slide on the new grip, and trigger sleeve. Applying talc or evaporating solvent to the inside will ease installation. Position the trigger guard on the handle. Thread the two new screws into the handle. Apply threaded locker to the two new button screws and thread into the handle. Before reinstalling the inlet connector, wrap the treads with Teflon tape to prevent galling the threads and to insure an air-tight connection. Tighten by wrench.

Part #	Description
HT57	1" ID x 10 FT LIGHTWEIGHT AIR SUPPLY HOSE
HT101	AIR-SPADE 2000 UTILITY/CONSTRUCTION KIT WITH 60 SCFM NOZZLE
HT102	AIR-SPADE 2000 UTILITY/CONSTRUCTION KIT WITH 225 SCFM NOZZLE
HT106	AIR-SPADE 2000 UTILITY/CONSTRUCTION KIT WITH 150 SCFM NOZZLE
HT107	AIR-SPADE 2000 ARBOR/LANDSCAPE KIT WITH 150 SCFM NOZZLE
HT108	AIR-SPADE 2000 TRENCH RESCUE KIT WITH 60 SCFM AND 150 SCFM NOZZLES
HT109	AIR-SPADE 2000 ARBOR/LANDSCAPE KIT WITH 225 SCFM NOZZLE
HT111	1" ID x 25 FT LIGHTWEIGHT AIR SUPPLY HOSE
HT112	1" ID x 50 FT LIGHTWEIGHT AIR SUPPLY HOSE
HT113	1" ID x 50 FT AIR SUPPLY HOSE
HT114	AIR-SPADE 2000 UTILITY/CONSTRUCTION KIT WITH 105 SCFM NOZZLE
HT116	AIR-SPADE 2000 150 SCFM NOZZLE WITH 3 FT BARREL
HT117	AIR-SPADE 2000 HANDLE ASSEMBLY
HT118	AIR-SPADE 2000 4 FT BARREL WITH DIRT SHIELD
HT119	AIR-SPADE 2000 45 DEGREE ANGLED ADAPTER
HT120	AIR-SPADE 2000 5 FT EXTENSION WITH COUPLER
HT121	AIR-SPADE 2000 3 FT EXTENSION WITH COUPLER
HT122	AIR-SPADE 2000 2 FT EXTENSION WITH COUPLER
HT123	AIR-SPADE 2000 150 SCFM NOZZLE
HT125	AIR-SPADE 2000 60 SCFM NOZZLE
HT126	AIR-SPADE 2000 25 SCFM NOZZLE
HT127	AIR-SPADE 2000 225 SCFM NOZZLE
HT129	AIR-SPADE 2000 150 SCFM NOZZLE WITH 40" BARREL
HT130	AIR-SPADE 2000 150 SCFM NOZZLE WITH 4 FT BARREL
HT131	AIR-SPADE 2000 150 SCFM NOZZLE WITH 3 FT BARREL
HT132	AIR-SPADE 2000 STORAGE CASE WITH LOCK
HT133	AIR-SPADE 2000 SLIDING DIRT SHIELD ASSEMBLY
HT134	AIR-SPADE 2000 60 SCFM NOZZLE WITH 4 FT BARREL
HT135	AIR-SPADE 2000 PRESSURE GAUGE
HT136	FACE SHIELD & HEADGEAR
HT138	AIR-SPADE 2000 225 SCFM NOZZLE WITH 4 FT BARREL
HT139	AIR-SPADE 2000 105 SCFM NOZZLE WITH 4 FT BARREL
HT140	AIR-SPADE 2000 25 SCFM NOZZLE WITH 4 FT BARREL
HT150	AIR-SPADE 2000 HANDLE SPARE PARTS KIT
HT154	AIR-SPADE 2000 4 FT EXTENSION WITH COUPLER
HT156	AIR-SPADE 2000 105 SCFM NOZZLE
HT165	AIR-SPADE 2000 3/4" FNPT NOZZLE ADAPTER
HT171	STORAGE BAG, CANVAS
HT180	AIR-SPADE 2000 AUXILIARY HANDLE ASSEMBLY
LT24	AIR-SPADE 3000 330 SCFM NOZZLE
LT3000	AIR-SPADE 3000 330 SCFM NOZZLE WITH 55" BARREL, 4-PRONG CONNECTOR
LT3000J01	AIR-SPADE 3000 330 SCFM NOZZLE WITH 55" BARREL, 2-PRONG CONNECTOR

Limited Warranty



AIR-SPADE Series 2000 is warranted by GUARDAIR CORPORATION (GUARDAIR) against defects in material and workmanship for a period of one year. Defective units will be replaced or repaired at the option of GUARDAIR. The warranty period begins at the date of shipment of the tool from GUARDAIR or from GUARDAIR'S authorized distributor.

This warranty shall not be in effect if the tool is subject to misuse, negligence, or accident, or if it is configured, or used in any manner inconsistent with the directions set forth in this operator's manual. Wear and tear from normal use is not covered under this warranty.

Any and all claims for warranty consideration must be coordinated through GUARDAIR. Do not return the unit or parts without prior authorization. Upon obtaining authorization, returned units or parts must be postage prepaid.

The purchaser's recovery for damages resulting from any and all causes whatsoever, including, but not limited to, breach of contract, breach of warranty, negligence or strict product liability will be limited to the replacement of the components of the tool with respect to which losses or damages are claimed, provided that GUARDAIR has been notified of any alleged defect within the warranty period.

IN NO EVENT SHALL GUARDAIR CORPORATION BE LIABLE TO THE PURCHASER OR ANY USER OF THE AIR-SPADE, OR TO ANY OTHER PERSON OR ENTITY, FOR INDIRECT, INCIDENTAL, OR CONSEQUENTIAL DAMAGES INCLUDING THE COST OF PROVIDING SUBSTITUTE EQUIPMENT DURING PERIODS OF MALFUNCTION OR NONUSE AND DAMAGES FOR DELAY. THE WARRANTIES AND REMEDIES SET FORTH ABOVE ARE THE SOLE AND EXCLUSIVE WARRANTIES AND REMEDIES AVAILABLE. GUARDAIR CORPORATION SPECIFICALLY DISCLAIMS ALL IMPLIED WARRANTIES OF MERCHANTABILITY AND FITNESS FOR A PARTICULAR PURPOSE AND ALL OTHER WARRANTIES, WHETHER EXPRESS, IMPLIED OR STATUTORY.



**The Most Powerful,
Compressed
Air-Powered,
Excavation Tool
Available On the
Market Today.**

**Featuring
the Patented
AIR-SPADE
Supersonic
Nozzle**

*For the
biggest,
toughest
excavation
jobs...*

**AIR-SPADE
3000**

**CHECK IT OUT AT:
www.air-spade.com**

AIR-VAC[®]

The Perfect Companion for AIR-SPADE[®]

AIR-VAC is a powerful, portable, compressed air-powered vacuum unit capable of vacuuming loose soil from holes, trenches, or excavation sites. Used in conjunction with AIR-SPADE, the patented AIR-VAC is ideal for uncovering underground pipes, cables, and tree roots in a non-destructive manner.

- Vacuums 1 to 2 cubic feet per minute of materials such as dirt, sand, gravel, rocks, or water.
- Durable 100 gallon steel tank.
- Large dump door allows ease of emptying.
- Washable polyester filter insures dust-free operation. Filters 99.5% of particulate at 0.2 to 2 microns.
- Exhaust silencer for quiet operation.
- Removable injector stack for easy transportation and storage.
- Designed for operation with a standard 185 scfm tow-behind compressor. *(Larger scfm units also available)*



AIR-SPADE[®]

54 Second Ave. Chicopee MA 01020

Phone: (800) 482-7324

Fax: (413) 594-4884

For more information visit us at:

www.air-spade.com

A DIVISION OF

GUARDAIR[®]
CORPORATION