

10 Cu. Ft. Dual Wheel Poly Tray Wheelbarrow

Read all instructions before starting. Please check to make sure that all parts have been included from the parts listing. Clear a flat work surface and allow for room to assemble wheelbarrow. It is best to secure but not completely tighten nuts until all assemble is complete.

For any questions contact customer service at 800-543-8955.

1 Insert (4) 3" large head carriage bolts through holes on inside of tray bottom and secure head to tray with masking tape. Use the same procedure for the (2) 3/4" large head carriage bolts on front of tray. Lay the tray upside down on a flat work surface.

2 Place (1) front and (1) rear steel tray supports over the 4 bolts extended through the tray bottom from step 1. (Flat side of support towards tray.)

3 Separately, assemble both legs and leg braces using the (4) 3/4" machine bolts, washers, and nylon lock nuts. The flat surface of the leg brace will mount to the inside of the legs.

4 Position the handles onto the (4) bolts that are installed in the tray and through the tray supports. Attach the nose brace to outside of handle and secure with (2) 2 1/4" bolts, washers, and nylon lock nuts. Only secure one bolt at the end hole of each handle for now.

5 Position large U-brace under front tray lip. Extend other end down to second set of nose brace holes at inside of handle and secure with remaining 2 1/4" bolts, washers, and nylon lock nuts.

6 Position the leg assembly and cross brace assembly onto the (4) bolts extending through tray, tray supports, and handles. Then secure with serrated flange nuts.

7 Position the (2) front tray braces onto the 3/4" bolts already secured in tray and install serrated flange nuts. Do not attach tray brace to handles yet.

8 Slide axle bracket on each end of the axle. Position this assembly over handle and line up holes in tray brace and handle, then hand tighten with (4) 3" bolts, washers, and nylon lock nuts. Slide a wheel assembly onto each side of axle. (air valve towards the outside.) Install cotter pin into axle. Center wheel and axle assembly by sliding axle brackets side to side. Allow 1/16" gap between axle brackets and wheel assembly. Tighten bolts.

9 Turn wheelbarrow right side up on a flat surface and tighten remaining hardware securely.

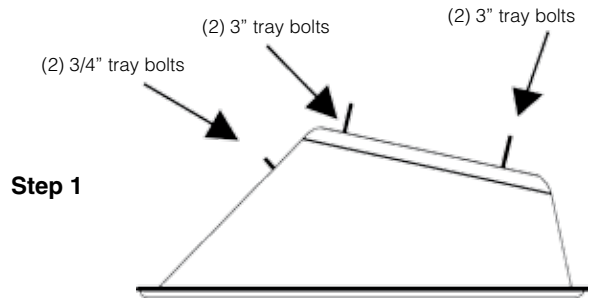

Step 1

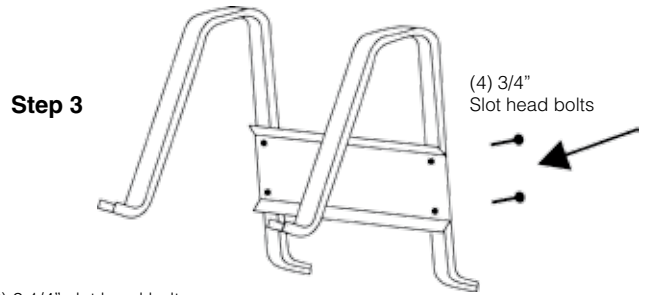

Step 3

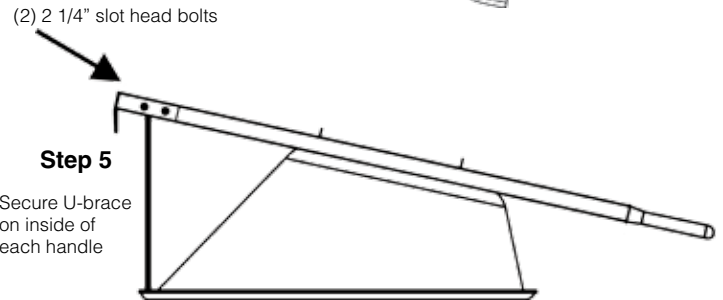

Step 5

Secure U-brace on inside of each handle

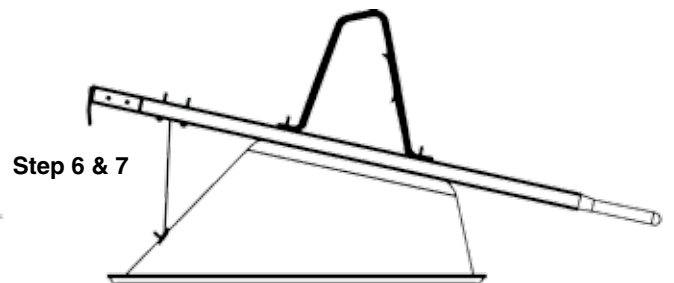

Step 6 & 7

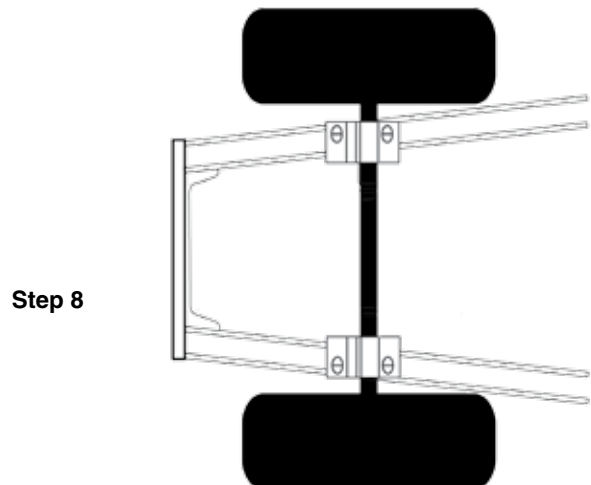

Step 8

EST. 1885
A.M. LEONARD
 HORTICULTURAL TOOL & SUPPLY COMPANY



DESCRIPTION	ITEM #	QTY.
10 cubic ft Poly tray	WB1099	1
Nose Brace	WB1001	1
Leg Brace	WB1002	1
Legs	WB1003	2
Handle 1 3/4" x 2"	WB1004	2
Wheel Assembly	WB1005	2
Axle Bracket	WB1098	2
Front Tray Brace	WB1007	2
Axle	WB1097	1
Front Tray Support	WB1009	1
Rear Tray Support	WB1010	1
Hardware Bag	WB1095	1
Tray U-Brace	WB1096	1

EST. 1885
A.M. LEONARD
 HORTICULTURAL TOOL & SUPPLY COMPANY

P.O. Box 816
Piqua, Ohio 45356-0816
Phone: 800-543-8955
Fax: 800-433-0633
Web: amleo.com