

## TL4000

**Easily change belts, blades  
and service front & rear tires**

**Tractor Lift can be used out of the box on most tractor brands available through major retailers. Tractor Lift mounting hardware is provided if your tractor does not have a bumper or brush guard.**

### Maintenance

Store in a clean dry place.

Recommended tire pressure - 30 PSI.

Before each use:

Always check tire pressure.

Always inspect unit for damage.

Always check fasteners for tightness.

### Tools required for assembly:

1. 9/16" wrench and/or socket
2. Adjustable wrench
3. Pliers

**If there are any missing parts, or if you have any questions on assembly, operation, maintenance or safety, please call 800-652-2321**



### WARNINGS

- Always use the stabilizer bar provided when using tractor lift.
- Make sure stabilizer bar is properly in place before starting any work on tractor.
- Read and understand all safety and operating instructions before using the tractor lift. Never allow anyone unfamiliar with these instructions to use the tractor lift.
- Read and understand all safety and operating instructions provided by the tractor's manufacturer before using tractor lift.
- Never lay under the tractor or mowing deck.
- When using lift, keep all bystanders, including children, away.
- This tractor lift must be only used for lifting and lowering to and from a level and stable surface.
- Never use in wet conditions.
- Do not attempt to lift the front and back of the tractor at the same time.
- Do not use tractor lift as an automotive lift, or for any other use for which it is not intended or designed.
- If tractor lift is bowing while lifting or lowering your tractor, which indicates an overload condition, remove the tractor immediately.
- Do not attempt to lift or lower any power equipment while motor is running.
- Never engage blades while using tractor lift.
- Always disconnect spark plug wire from tractor before beginning any work on tractor.
- Do not exceed the rated capacity of the tractor lift - 270#.
- Failure to follow these warnings may result in property damage and/or serious bodily injury.

### SAFETY INSTRUCTIONS

- Be sure to read and follow all safety instructions and warnings. Failure to follow these instructions may result in damage to the product and/or serious personal injury.
- Danger of serious personal injury exists. Serious personal injury can occur when using a lifting device.
- Never attempt to ride any vehicle up or down the tractor lift.
- Do not climb onto tractor while tractor is in the elevated position.
- When working on the front of the tractor always place wheel chocks in back of the rear wheels/tires.
- Always raise and lower tractor lift in a controlled fashion; do not allow the tractor to drop too quickly, damage could occur.
- Make sure lifting arms are aligned and set to the proper distance apart so that the equipment being loaded is well balanced on the lift.
- Do not remove warning decals from product.
- Before each use, always check for any worn, loose, or damaged parts on the tractor lift. If any damage is present, DO NOT USE THE TRACTOR LIFT.
- Periodically check the fasteners to make sure they are still tight and in place.
- Keep lift surface clean by occasionally cleaning with water and any mild detergent.
- Do not add to or try to modify the tractor lift in any way. Any modifications will void any warranties.
- Failure to abide by the warnings and read the safety instructions may result in loss of load, damage to lift and/or property, serious personal and/or fatal injury.

# CARTON CONTENTS

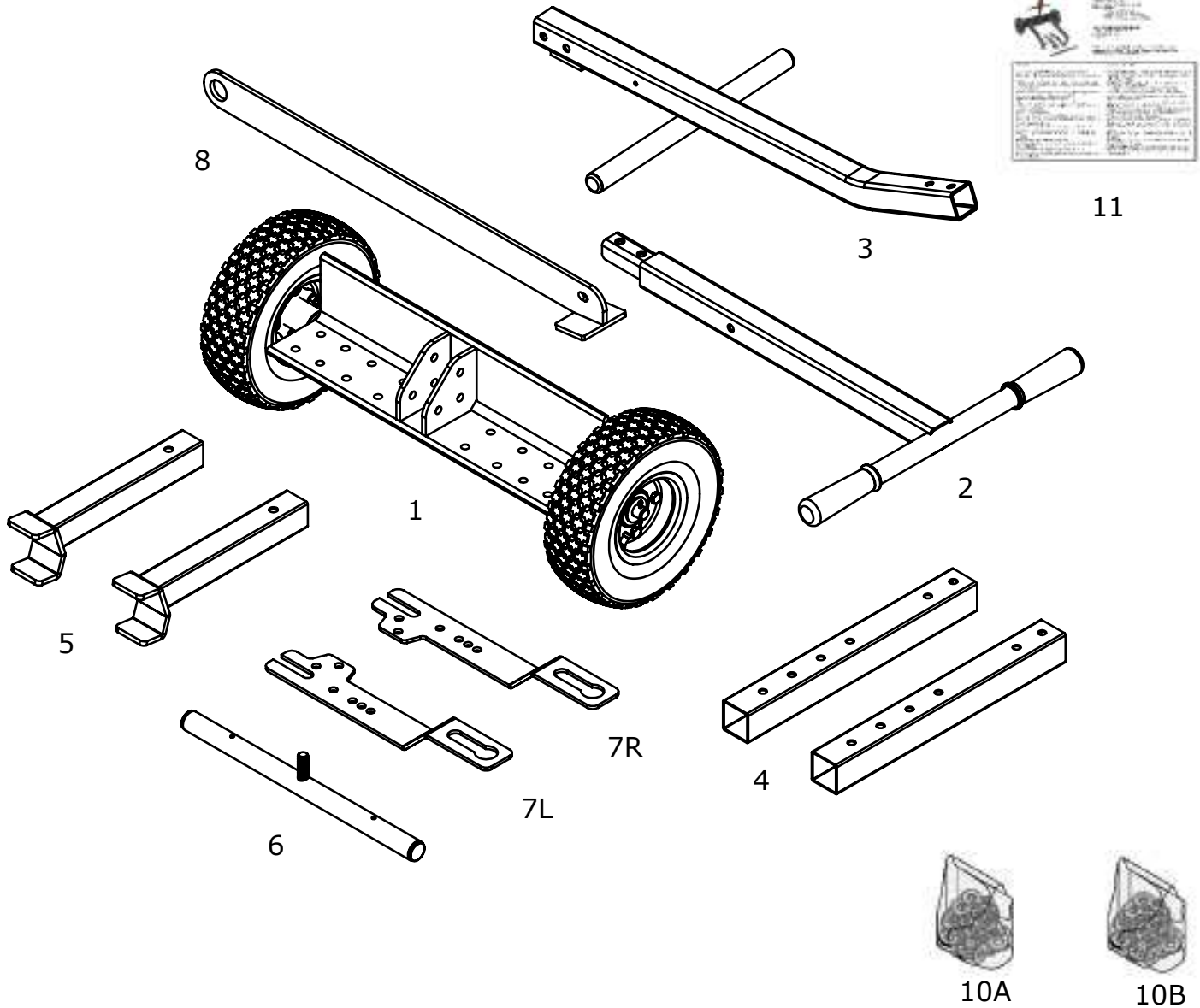

REF NO	QTY	DESCRIPTION	REF NO	QTY	DESCRIPTION
1	1	Angle Frame	7L	1	Tractor Brkt Left
2	1	Handle Top	7R	1	Tractor Brkt Right
3	1	Handle Bottom	8	1	Stabilizer Bar
4	2	Receiver Tube	10A	1	Hardware Bag #1
5	2	Lift Arm Tube	10B	1	Hardware Bag #2
6	1	Lift Cross tube	11	1	Assembly Guide

## TOOLS REQUIRED FOR ASSEMBLY

9/16" Wrench and/or Socket  
Adjustable wrench  
Pliers

## MAINTENANCE

Store unit in a clean dry place.  
Recommended tire pressure - 30 PSI.  
Before each use:  
Always check tire pressure.  
Always inspect unit for damage.  
Always check fasteners for tightness.

## HARDWARE CONTENTS - BAG #1

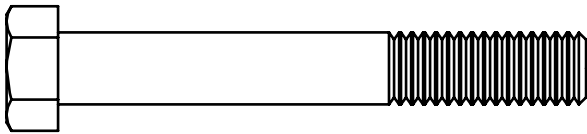

22

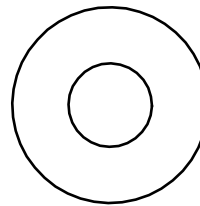

24

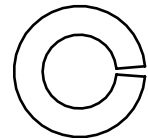

23

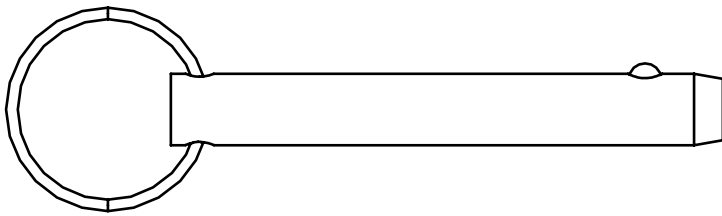

30

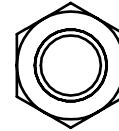

25



39

## HARDWARE CONTENTS - BAG #2

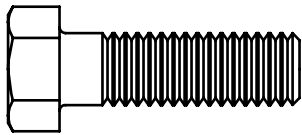

29



35

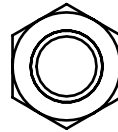

27

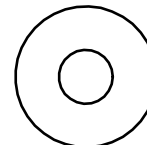

36

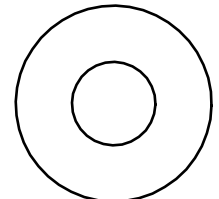

24

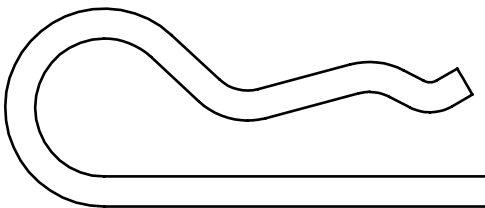

26

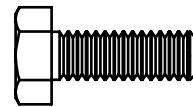

34

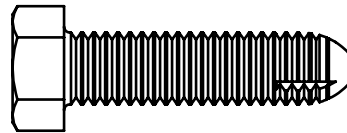

28

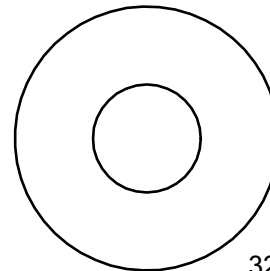

32

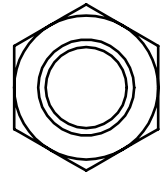

31

## HARDWARE CONTENTS - BAG #1

## HARDWARE CONTENTS - BAG #2

REF NO	QTY	PART NUMBER	DESCRIPTION	REF NO	QTY	PART NUMBER	DESCRIPTION
22	6	310051	3/8" -16 x 2-3/4" Hex Bolt	24	2	310073	3/8" USS Flat Washer
23	9	310072	3/8" Split Lock Washer	26	2	300082	Hair Pin Cotter .148 Dia.
24	7	310073	3/8" USS Flat Washer	27	4	310061	3/8"-16 Nylok Hex Nut
25	7	310062	3/8" -16 Hex Nut	28	2	310054	3/8"-16 x 1-1/2" Self Thread
30	3	310081	3/8" Ring Grip Pin	29	6	310055	3/8"-16 x 1-1/4" Hex Bolt
39	1	310064	3/8" Wing Nut	31	1	310063	1/2"-13 Hex Nut
				32	1	310074	1/2" USS Flat Washer
				34	4	3000538	1/4"-20 x 3/4" Hex Bolt
				35	4	310065	1/4"-20 Nylok Hex Nut
				36	4	310075	1/4" USS Flat Washer

## Assemble Tractor Lift

### Attach Lift Tubes to Angle Frame

- Attach Receiver Tubes ( 4 ) to angle frame ( 1 ) using bolts ( 22 ), flat washers ( 24 ), split lock washers ( 23 ) and hex nuts ( 25 ).
- Slide Lift Arm Tubes (5) into Receiver Tubes (4) secure with Ring Grip Pins (30).

Note: Over-tightening receiver bolts ( 22 ) could cause damage to lift tubes ( 4 ).

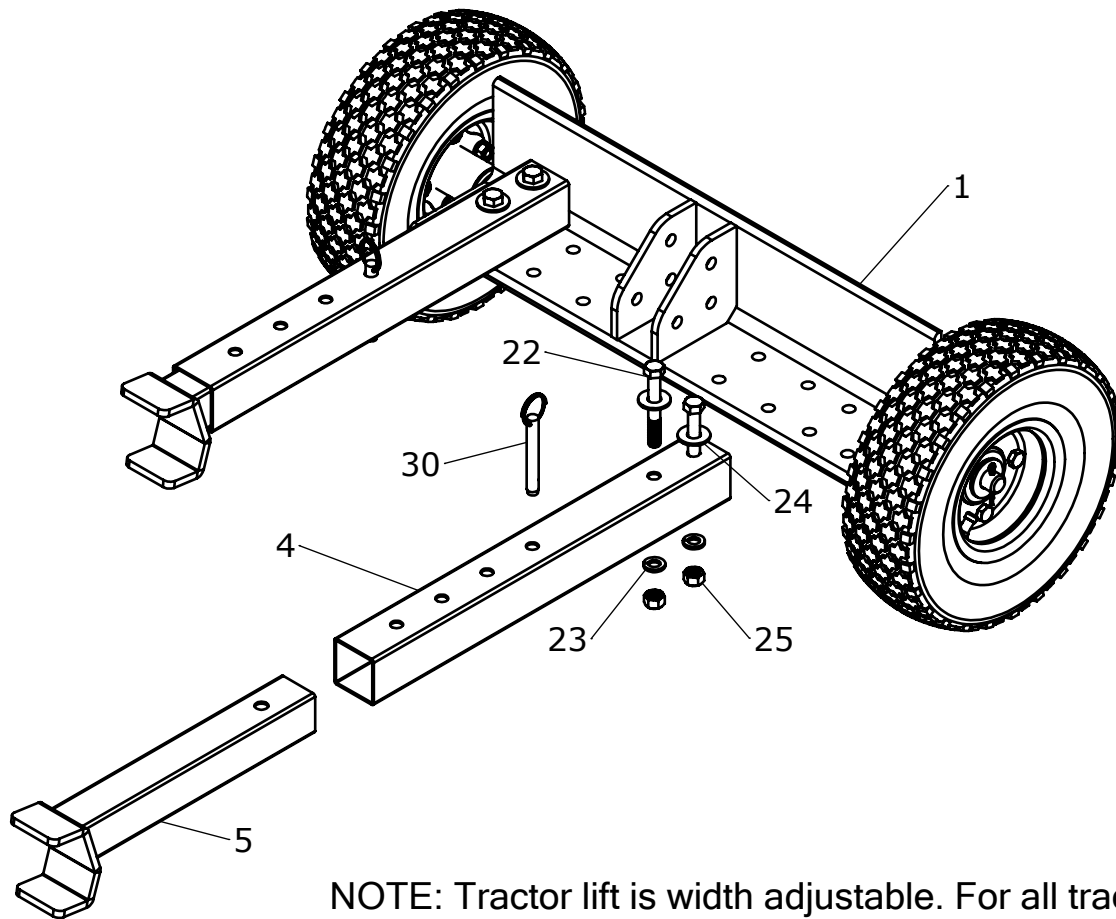

NOTE: Tractor lift is width adjustable. For all tractors, the lifting claws will engage lifting bar similar to STEP 1 on page 9.

# Assemble Tractor Lift

## Attach Handle to Angle Frame

- Step 1. Attach handle bottom ( 3 ) to angle frame ( 1 ) using hex bolt ( 22 ), flat washer ( 24 ), split lock washer ( 23 ) and hex nut ( 25 ).
- Step 2. Insert ring grip pin ( 30 ), as shown.
- Step 3. Insert handle top ( 2 ) into handle bottom ( 3 ). Secure with hex bolts ( 29 ) and split lock washers ( 23 ).
- Step 4. Slide stabilizer bar ( 8 ) onto Foot Bar Tube. Insert hex bolt ( 22 ) and flat washer ( 24 ) through side of handle top ( 2 ). Tighten using split lock washer ( 23 ) and hex nut ( 25 ).
- Step 5. Align hole in stabilizer bar ( 8 ) with hex bolt ( 22 ). Tighten using wing nut ( 39 ).

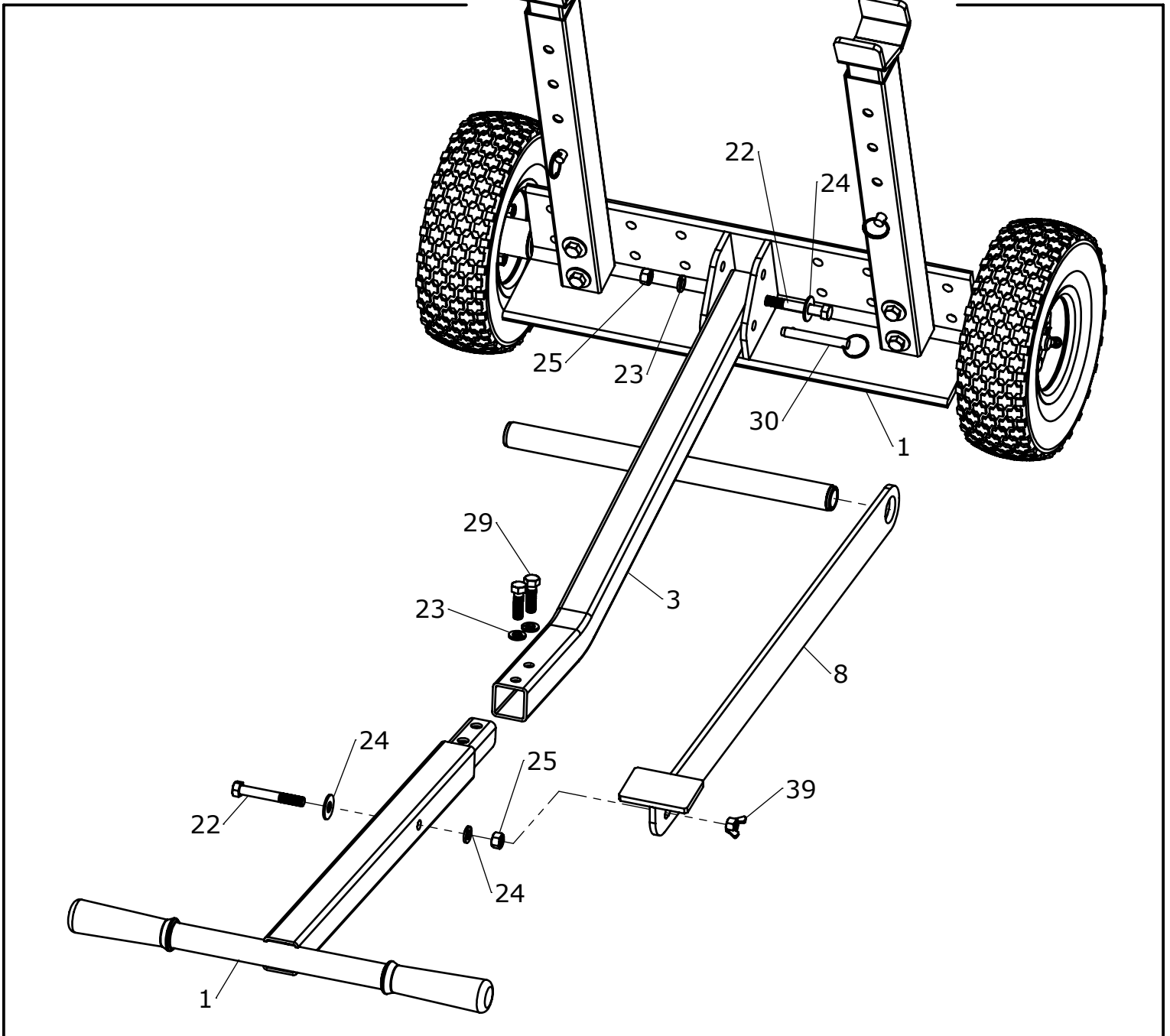

# Installing Front Lift Brackets

(if tractor is equipped with a tube style bumper, then this step is not required)



**Refer to pages 7-8 for specific tractor models.**

Slide lifting bracket onto existing shoulder bolt. Remove self-tapping screw with 9/16" socket. Align hole in bracket with hole in tractor frame. Replace self-tapping screw. Repeat for opposite side.



Slide lifting bar through both lifting brackets.



When lifting bar is through both brackets, push hair pin cotter through holes found in lifting bar. This will keep lifting bar from sliding out of brackets.



This is how the tractor should look when installation is complete.

# Installing Rear Lift Bar



Remove hair pin cotter from lifting bar. Slide bar out of lifting brackets.



Remove nut and washer from threaded stud. Slide threaded stud through hitch pin hole. Replace nut and washer.



Tighten nut with a 3/4" wrench. Installation is now complete.

## Tractor Specific Installation

Tractor Lift can be used out of the box on any tractor equipped with a tubular front bumper or brushguard. If your tractor does not have a bumper or brush guard, please read the configuration legend and follow the steps below for your model of tractor:

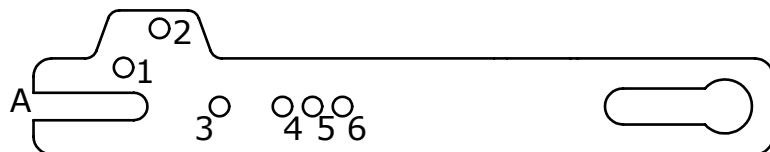

### CONFIGURATION LEGEND:

For the different models of tractors, different holes in the tractor bracket will be used. To help understand the appropriate configuration for your type of tractor, the legend represents all the holes as numbers with the addition of the letter A as the slot.

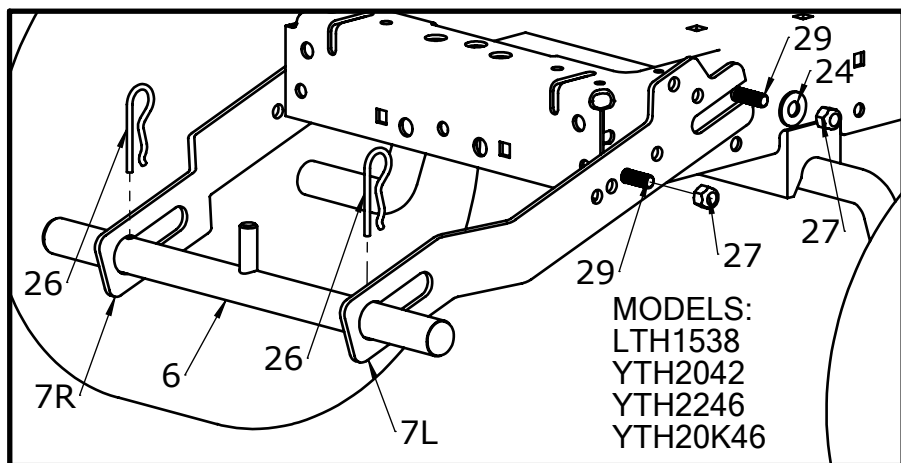

### HUSQVARNA®

- Insert bolt ( 29 ) through inside front hole of frame, through #4 hole in tractor bracket ( 7 ) and secure with nyloc nut ( 27 ).
- Insert bolt (29) through inside back hole of frame, through slot A in tractor bracket (7), add washer (24) and secure with nyloc nut (27).
- Refer back to STEP 2 on page 6 of the Assembly Guide.

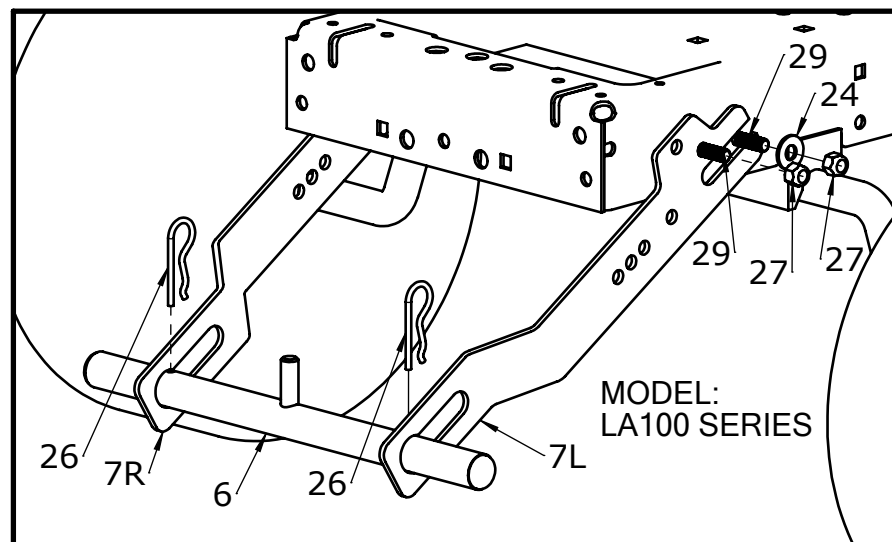

### JOHN DEERE®

- Insert bolt ( 29 ) through inside front hole of frame, through #1 hole in tractor bracket ( 7 ) and secure with nyloc nut ( 27 ).
- Insert bolt (29) through inside back hole of frame, through slot A in tractor bracket (7), add washer (24) and secure with nyloc nut (27).
- Refer back to STEP 2 on page 6 of the Assembly Guide.

Continue...

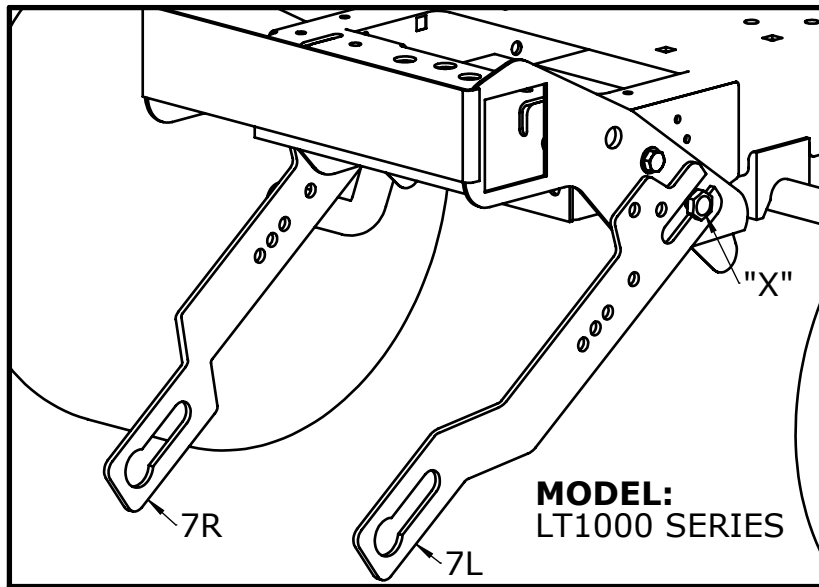

### CUB CADET®

Step 1:

- Using Slot A, slide tractor bracket (7) onto existing shoulder bolt ("X")

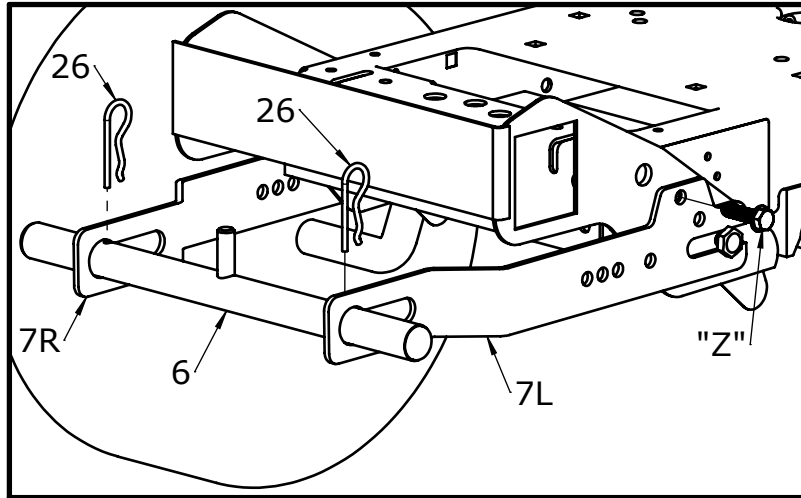

Step 2:

- Remove 1/2" screw bolt ("Z"). Align #2 hole in tractor bracket (7) with threaded hole in frame, replace screw bolt and tighten to frame. If tractor does not have Bolt "Z", use supplied 3/8" x 1-1/2 Self Threading bolt (28)
- Refer back to STEP 2 on page 6 of the Assembly Guide.

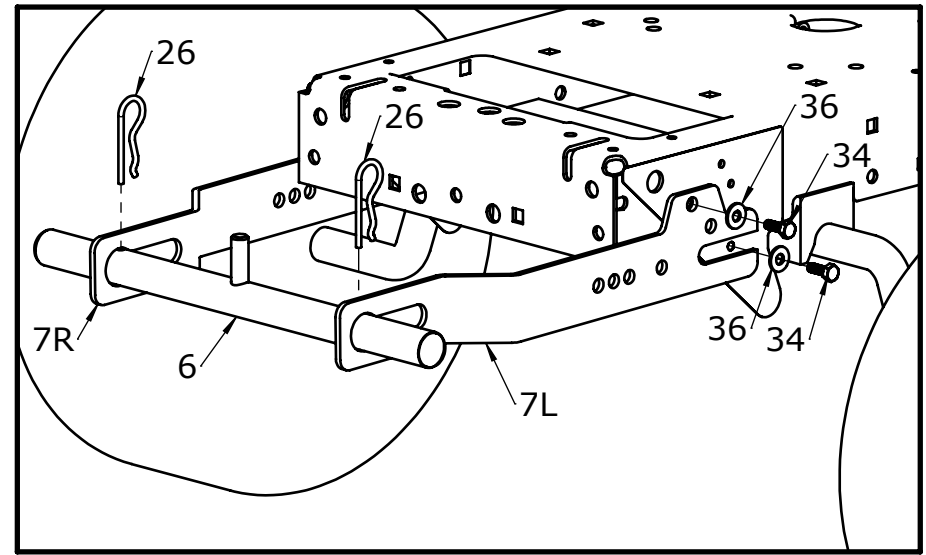

### WHITE OUTDOOR®, HUSKEE®, HUSKEE SUPREME®, TORO®, TROY BILT®, YARD MACHINE®

- Insert bolt (40) through #2 hole in tractor bracket (7), through outside front hole of frame, and secure with nyloc nut (41).
- Insert bolt (40) with washer (42) through Slot A in tractor bracket (7), through outside back hole of frame, and secure with nyloc nut (41).
- Refer back to STEP 2 on page 6 of the Assembly Guide.



# Lifting Your Tractor (front)



Engage lifting claws to lift bar



Place foot onto footbar while keeping lifting claws engaged to lift bar.



A. Apply slow continuous pressure to foot bar while bringing the handle towards the ground.  
B. While applying pressure with foot, bring the handle slowly towards the ground.



The tractor lift is securely in place when the curve in the handle is resting flat on the ground.

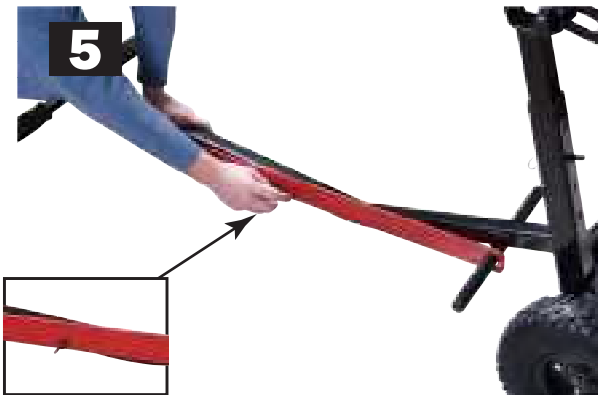

Remove wingnut from stabilizer holder bolt.



Slide stabilizer bar off footbar. Replace wingnut. Rotate stabilizer bar so stabilizer bar foot pad is resting on the ground. Slide stabilizer bar back onto footbar. Stabilizer bar should properly be in place under the tractor.

## Service Parts List

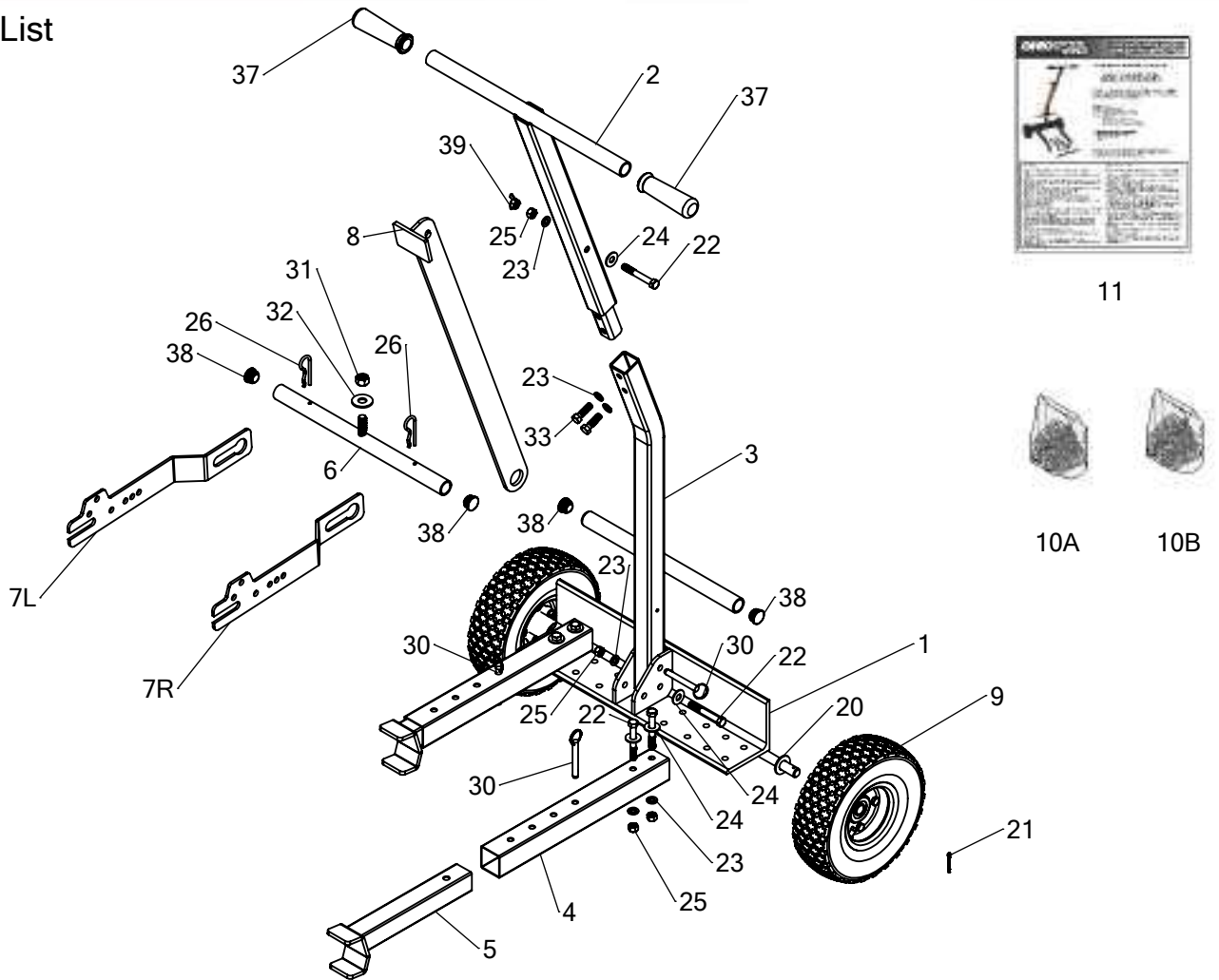

REF. NO.	PART NO.	AMT.	DESCRIPTION	REF. NO.	PART NO.	AMT.	DESCRIPTION
1	510011	1	Angle Frame	24	310073	9	3/8" USS Flat Washer
2	510024	1	Handle Top	25	310062	7	3/8"-16 Hex Nut
3	510032	1	Handle Bottom	26	300082	2	Hair Pin Cotter .148 DIA.
4	410091	2	Receiver Tube	27	310061	4	3/8"-16 Nylok Hex Nut
5	510041	2	Lift Arm Tube	28	310054	2	3/8"-16 x 1-1/2" Self Thread
6	510051	1	Lift Cross Tube	29	310055	6	3/8"-16 x 1-1/4" Hex Bolt
7L	410131	1	Tractor Mtg Bracket - Left	30	310081	3	3/8" x 2-1/8" Ring Grp Pin
7R	410132	1	Tractor Mtg Bracket - Right	31	310063	1	1/2"-13 Hex Nut
8	51006	1	Safety Bar	32	310074	1	1/2" USS Flat Washer
9	310011	2	Tire 4.10/3.50-4	34	3000538	4	1/4"-20 x 3/4" Hex Bolt
10A	310039	1	Hardware Bag #1	35	310065	4	1/4"-20 Nylock Hex Nut
10B	3100310	1	Hardware Bag #2	36	310075	4	1/4" USS Flat Washer
11	310042	1	Assembly Manual	37	310181	2	Vinyl Handle Grp
20	310071	4	5/8" SAE Flat Washer	38	310221	4	Tube Plug RT8-1
21	300081	2	Cotter Pin 1/8" x 1-1/2"	39	310064	1	3/8"-16 Wing Nut
22	310051	6	3/8"-16 x 2-3/4" Hex Bolt				
23	310072	9	3/8" Split Lock Washer				